

STAINLESS STEEL WAFER SPRING CHECK VALVE PN40

Wafer disc stainless steel check valve for drinking water, chemical and pharmaceutical industries, petrochemical industries, hydraulic installation, compressed air.

Stainless steel type with spring, all positions.

Metal/metal tightness (leakage rate according to API 598 standard).

Compatible with explosive atmosphere, ATEX Zone 1&21 and Zone 2&22.

Check valve in accordance with the regulation (EC) N° 1935/2004 on request.

ISO 9001 : 2015
BUREAU VERITAS
Certification



CE 1935/2004

Certificate
3.1



Size : DN15 to DN200

Connection : Between flanges PN10/16/25/40

Min Temperature : -20°C

Max Temperature : +400°C

Max Pressure : 40 Bars

Specifications : Spring disc type

All positions

Metal/metal tightness

Materials : Stainless steel EN 1.4408

STAINLESS STEEL WAFER SPRING CHECK VALVE PN40

SPECIFICATIONS :

- Spring type
- All positions (respect the flow direction indicated by the arrow)
- Short length
- Disc rib guide for a better centering
- Full stainless steel corrosion resistant and for high temperature
- Metal / metal tightness
- With guide from DN125 to 200

USE :

- Chemical and pharmaceutical industries, petrochemical industries, hydraulic installation, compressed air
- Min Temperature Ts : - 20°C
- Max Temperature Ts :+ 400°C
- Max Pressure Ps : 40 bars (see graph under)
- Steam : 14 bars max

PRESSURE / TEMPERATURE GRAPH (STEAM EXCLUDED)DN15-100 :

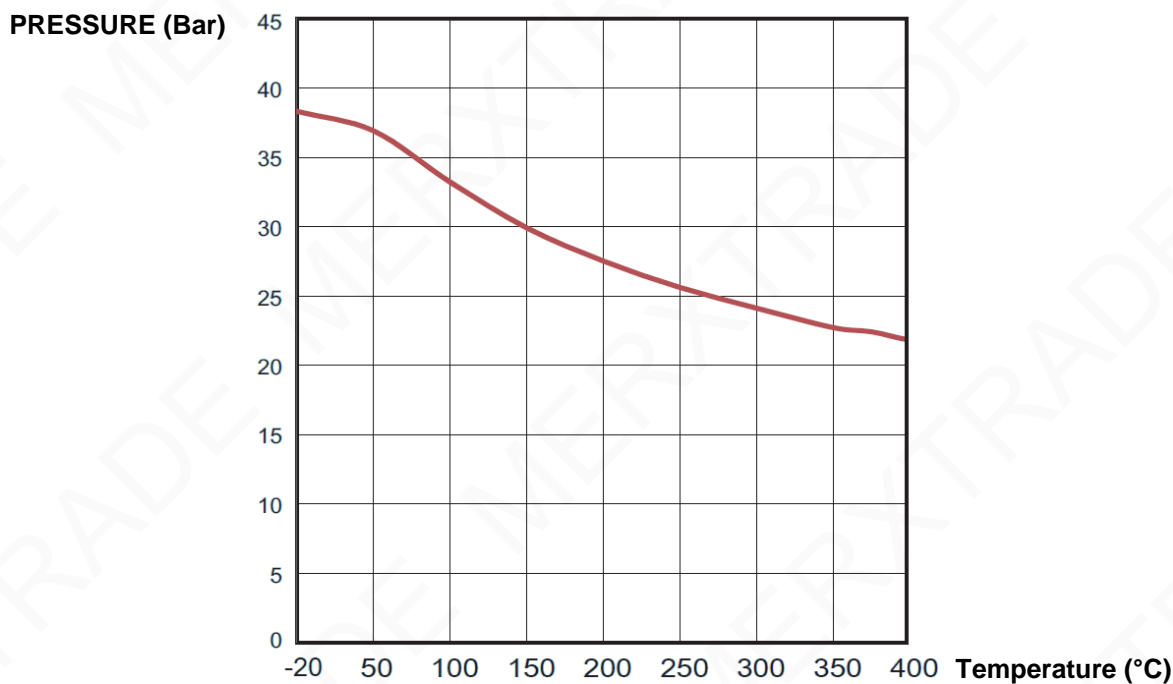

PRESSURE / TEMPERATURE RELATION DN125-200 :

Pressure (Bar)	39.2	38	33.3	30.4	28.2	26.3	25	24	23.2
Temperature (°C)	-10	50	100	150	200	250	300	350	400

FLOW COEFFICIENT Kvs (M3 / h) :

DN	15	20	25	32	40	50	65	80	100	125	150	200
Kvs (m3/h)	2.1	5.76	9.6	14.5	21.9	24.2	57.1	64.97	90.2	228	342.5	647.8

STAINLESS STEEL WAFER SPRING CHECK VALVE PN40

RANGE :

- Between PN10/16/25/40 flanges **Ref. 386** from DN15 to DN100
(*) : For an installation between flanges PN10/16 for DN100, we only use 4 bolts
- Between PN40 flanges and **Ref. 386** from DN125 to DN200

HEAD LOSS GRAPH :

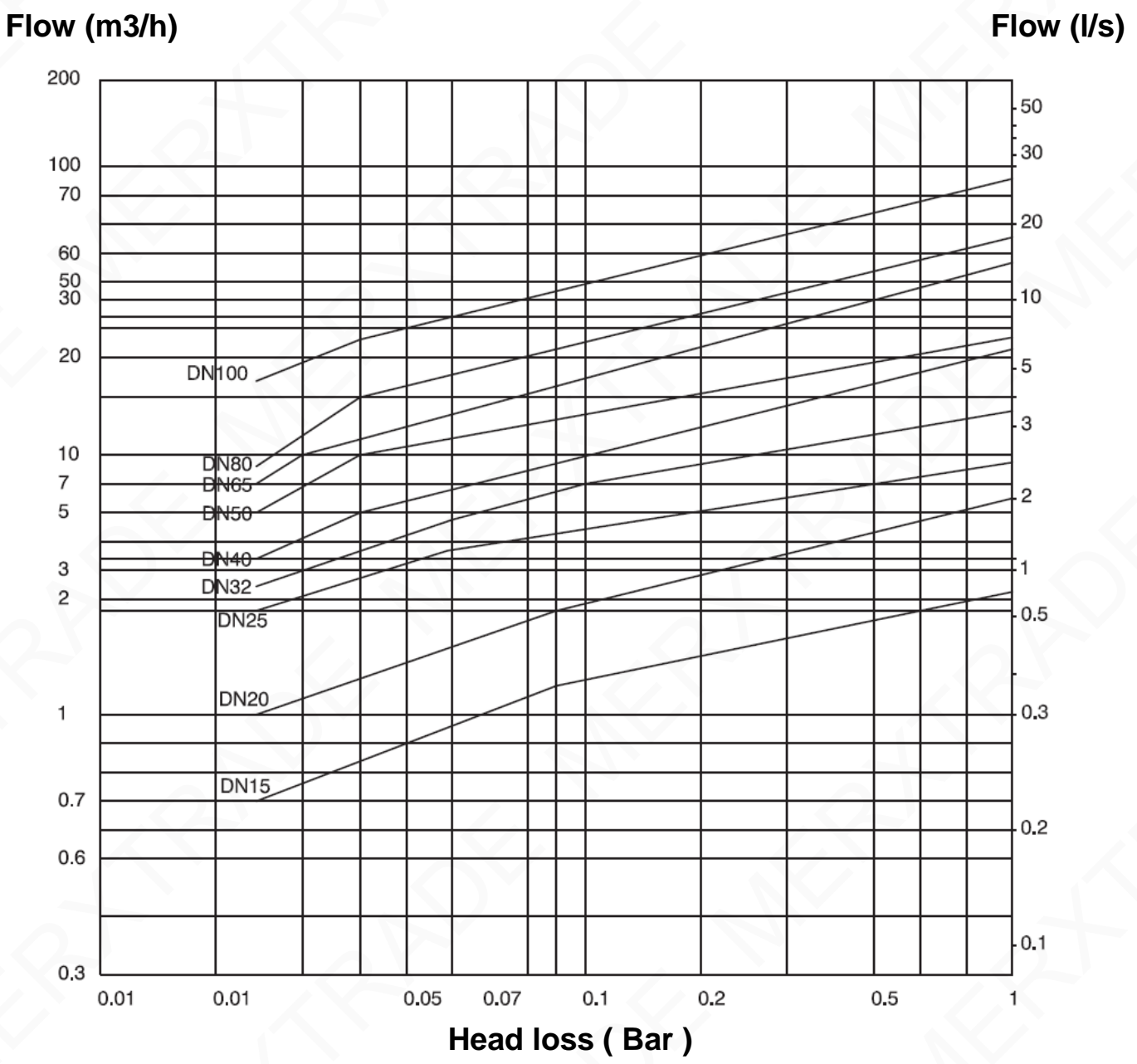

STAINLESS STEEL WAFER SPRING CHECK VALVE PN40

LEAKAGE RATE ACCORDING TO API 598 (DURING 60s excepted for DN200: 120s):

DN	8	10	15	20	25	32	40	50	65	80	100	125	150	200
Liquid Test (cc/min)	6								7.5	9	12	15	18	24
Gas Test (m3/h)	0.08								0.11	0.13	0.17	0.21	0.25	0.34

OPENING PRESSURE (in mbar) :

DN	Vertical Position Ascending Fluid	Horizontal Position
DN 15	25 ↑	23 →
DN 20	25 ↑	23 →
DN 25	25 ↑	23 →
DN 32	27 ↑	24 →
DN 40	29 ↑	25 →
DN 50	29 ↑	25 →
DN 65	31 ↑	25 →
DN 80	32 ↑	26 →
DN100	33 ↑	27 →
DN 125	60 ↑	51 →
DN 150	60 ↑	50 →
DN200	62 ↑	49 →

STAINLESS STEEL WAFER SPRING CHECK VALVE PN40

MATERIALS :

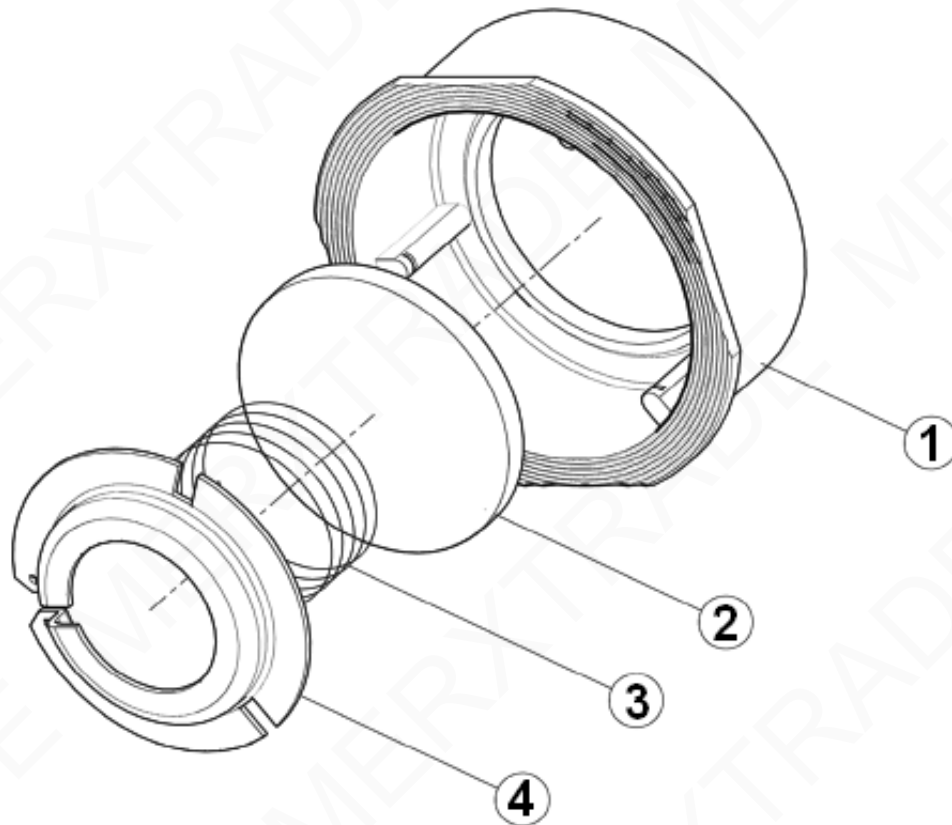

Item	Designation	Materials
1	Body	EN 1.4408
2	Disc	ASTM A240-316
3	Spring	AISI 316
4	Spring holder	ASTM A240-316

STAINLESS STEEL WAFER SPRING CHECK VALVE PN40

SIZE (in mm) DN15-100 :

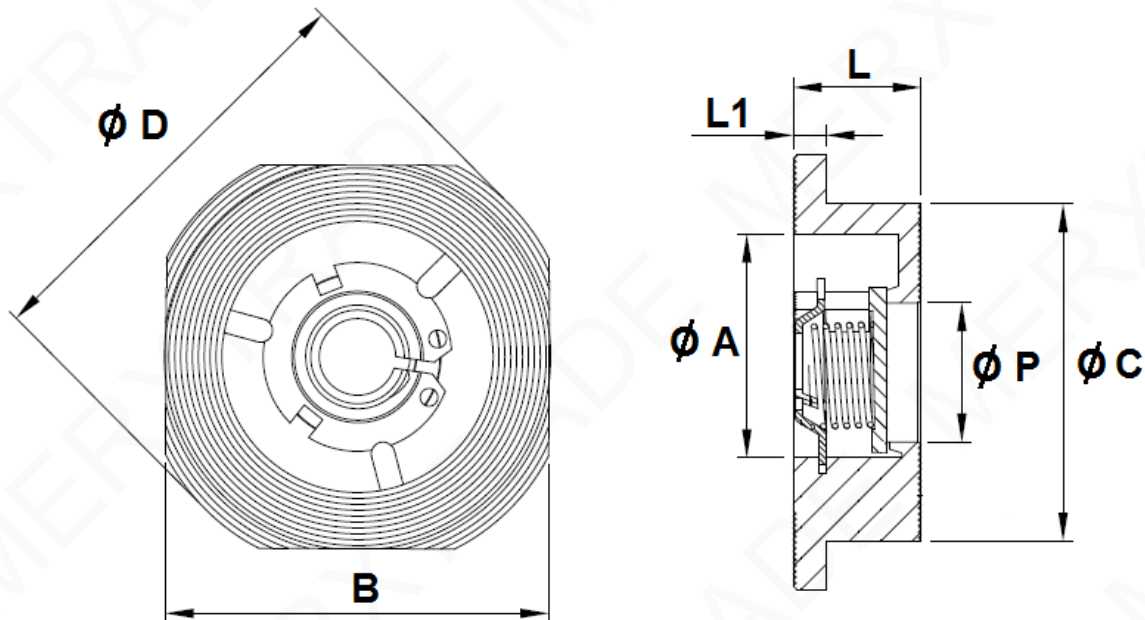

DN 15 – 80

DN100

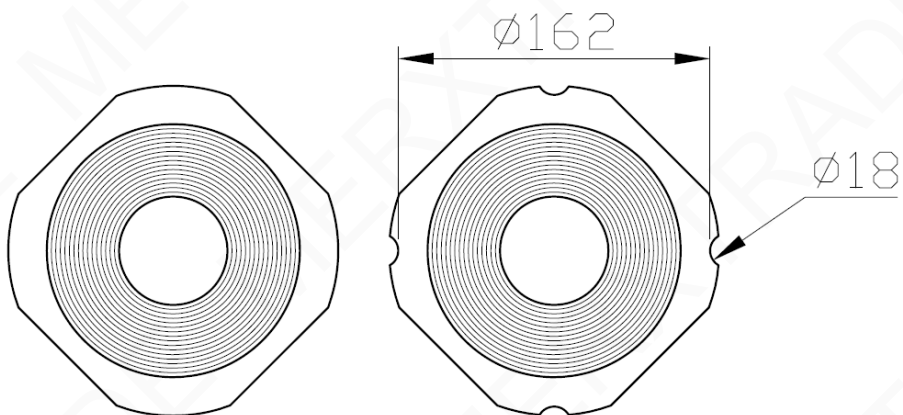

DN	15	20	25	32	40	50	65	80	100
Ø A	34	39	46	60	70	79	101	109	134
B	44.6	54	65	78	88	101.6	120.4	133	164
Ø C	40.5	47	56	70	80	90	113	123	150
Ø D	54	62	73	83	93	107	126.5	141.2	171.4
L	16	19	22	28	31.5	40	46	49	60
L1	3.5	3.5	4	5	5	5	5.5	5.5	6.5
Ø P	12.5	20	25	32	38	49	64	78	98
Weight (Kg)	0.1	0.15	0.24	0.5	0.55	0.83	1.4	1.77	2.97

STAINLESS STEEL WAFER SPRING CHECK VALVE PN40

SIZE DN125-200 (in mm) :

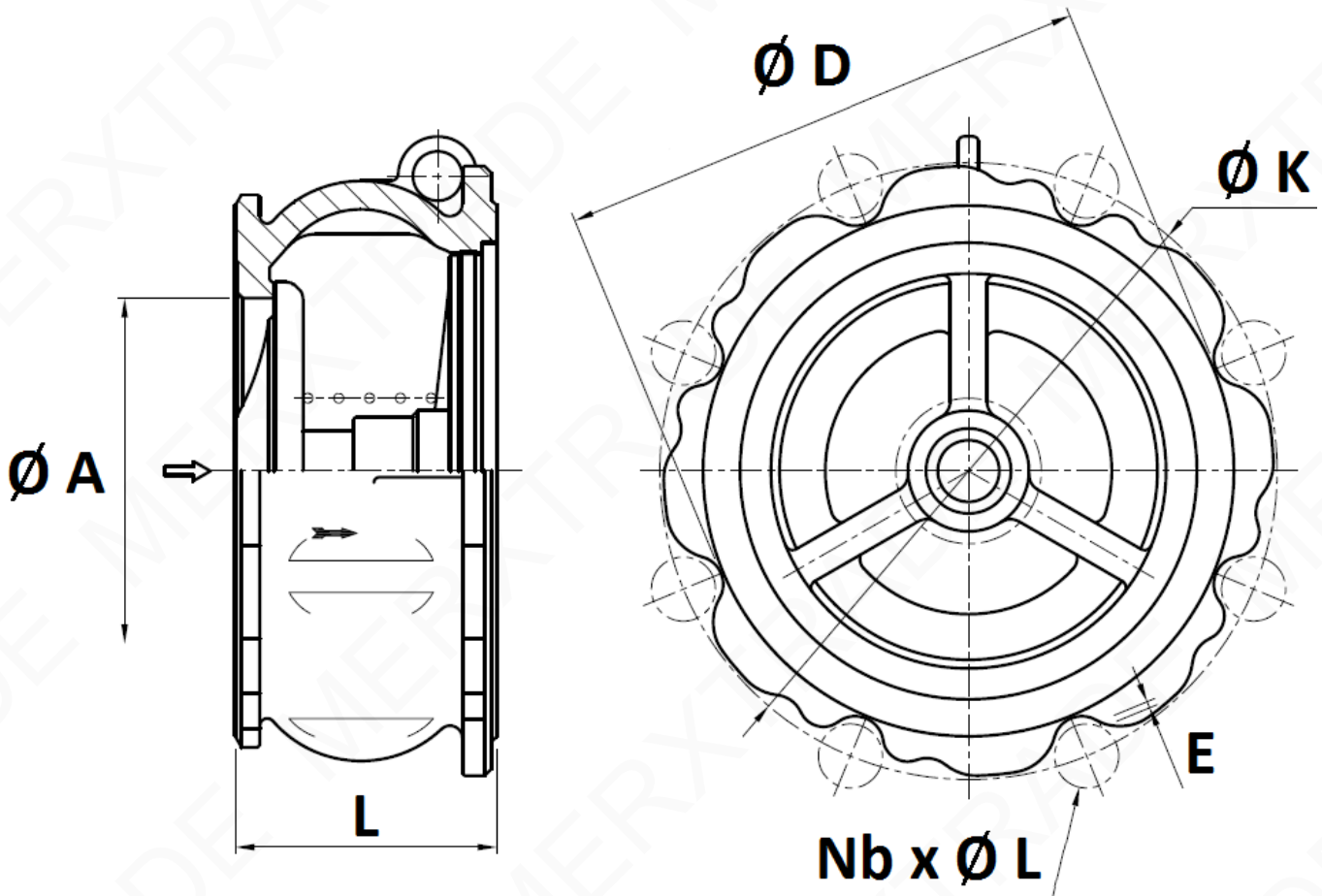

DN	125	150	200
L	90	106	140
Ø A	120	140	184
Ø D	186	216	267
Ø K	220	250	320
Nb x Ø L	8 x 26	8 x 26	12 x 30
E	3	2.7	10
Weight (in Kg)	8.34	13.4	24.2

STAINLESS STEEL WAFER SPRING CHECK VALVE PN40

STANDARDS :

- Manufacturer certified ISO 9001 : 2015
- DIRECTIVE 2014/68/EU : For liquids and gas of Group 1
 - DN8-25 : Article 4, §3 (SEP), no CE marking
 - DN32-100 : Risk Category II, CE 0035 marking
 - DN125-200 : Risk Category III, CE 0062 marking
- Certificate 3.1 on request
- Designing according to EN 12516-1
- Pressure tests according to API 598, table 6
- Length according to EN 558 series 49 (DIN 3202 K4)
- ATEX Group II Category 2 G/2D Zone 1 & 21 Zone 2 & 22 (optional marking)
- Drinking water compatibility
- Check valve in accordance with the regulation **(EC) N° 1935-2004 on request**

ADVICE : Our opinion and our advice are not guaranteed and merxtrade shall not be liable for the consequences of damages. The customer must check the right choice of the products with the real service conditions.

STAINLESS STEEL WAFER SPRING CHECK VALVE PN40

BOLTING POSTIONS :

- **BETWEEN PN10/16 FLANGES :**

DN 15 – 50

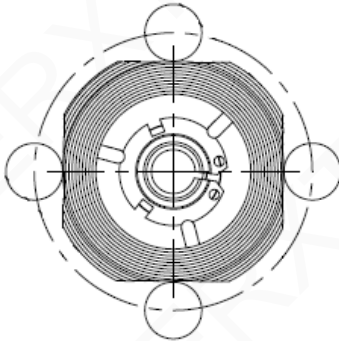

DN 65 – 80

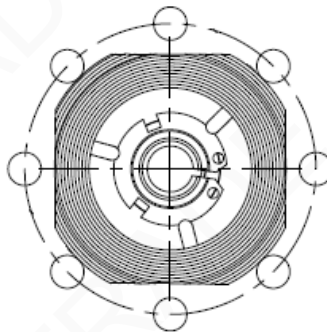

DN 100

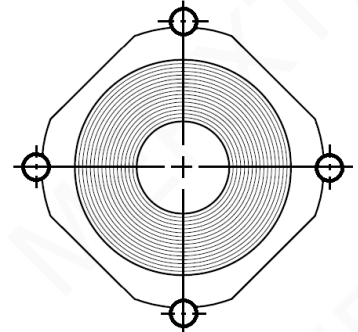

- **BETWEEN PN25/40 FLANGES :**

DN 15 – 50

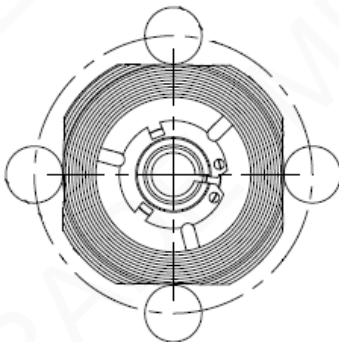

DN 65 – 100

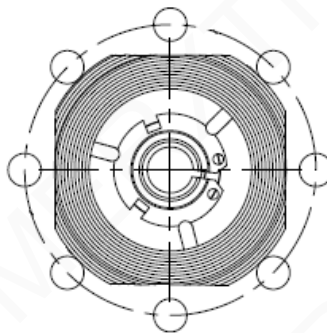

STAINLESS STEEL WAFER SPRING CHECK VALVE PN40

INSTALLATION INSTRUCTIONS

GENERAL GUIDELINES :

- Ensure that the check valves to be used are appropriate for the conditions of the installation (type of fluid, pressure and temperature).
- Be sure to have enough valves to be able to isolate the sections of piping as well as the appropriate equipment for maintenance and repair.
- Ensure that the valves to be installed are of correct strength to be able to support the capacity of their usage.

INSTALLATION INSTRUCTIONS :

- **Before installing the check valves, clean and remove any objects from the pipes** (in particular bits of sealing and metal) which could obstruct and block the valves.
- **Ensure that both connecting pipes either side of the check valve (upstream and downstream) are aligned (if they're not, the valves may not work correctly).**
- **Make sure that the two sections of the pipe (upstream and downstream) match, the check valve unit will not absorb any gaps. Any distortions in the pipes may affect the tightness of the connection, the working of the check valve and can even cause a rupture.** To be sure, place the kit in position to ensure the assembling will work.
- Make sure there is enough space so that the disc can be opened totally in the pipe.
- If there is a direction changing or if there's another material, it's better to take away the check valve so that it is outside the turbulence area (**between 3 and 5 times the ND before and after**).
- After a pump please refer to **FD CEN/TR 13932** to install the check valve :
 - If it is essential to keep priming the pump, a non-return check valve can be fitted to the suction pipe at a distance **L1 (straight length suction) > 10xD1 (diameter suction)**
The check valve is designed to meet the maximum flow rate in service
 - In other cases, the non-return check valve is mounted on the discharge pipe at a distance of **L2 (straight length at discharge) > 3xD2 (diameter at discharge)**